

METAL DETECTOR

METRON 05 CO

RELIABLE DETECTION OF ALL METALS:

- FERROUS
- STAINLESS STEEL
- ALUMINUM
- COPPER
- BRASS
-

RELIABLE DETECTION OF FREE OR
ENCAPSULATED CONTAMINANTS.

Version 07/11

**SPLINTER DETECTION MACHINE FOR INSTALLATION
IN BELT CONVEYORS.**

INDUSTRIES

- TIMBER INDUSTRY

APPLICATION

- MACHINERY PROTECTION
E. G. CUTTING RASTERS
- ...

**HIGHLY INTEGRATED „HIGH SPEED“ MULTI-PROCESSOR TECH-
NOLOGY AS NEED FOR A DIGITAL 2 CHANNEL SIGNAL PROCESSOR,
EVEN WITH VERY HIGH CONVEYOR SPEEDS OF UP TO 6 M/SEC.**

CONVINCING ARGUMENTS

- HIGHEST SENSITIVITY AND THEREFORE RELIABLE PROTECTION AGAINST MACHINERY DAMAGE. THE OCTAGONAL DETECTOR APERTURE SHAPE CONFORMS TO THE FEED TROUGH, THIS ASSURES OPTIMUM EFFICIENCY OF THE METAL DETECTOR.
- SIMPLE, 4 BUTTON OPERATION, VERY LEGIBLE, BACKLIT 4 ROW DISPLAY, OPERATOR FRIENDLY MENU STRUCTURE AND EASY TO UNDERSTAND TEXT INFORMATION FACILITATE INITIAL OPERATIONS.
- SAFETY FIRST! THE STAINLESS STEEL DETECTOR HOUSING OFFERS TWOFOLD ADVANTAGES. IT PROTECTS AGAINST CORROSION AND SHIELDS AGAINST INTERFERENCE. FOR THE ULTIMATE IN INTERFERENCE PROTECTION MESUTRONIC OFFERS THE "INTERFERENCE SHIELD", DEVELOPED AND EMPLOYED SUCCESSFULLY IN THE ROUGH WORLD OF SAWMILLS.
- ERRORS ARE ELIMINATED! THE OPTIONAL PAINT MARKING SYSTEM INDICATES AUTOMATICALLY AND PERMANENTLY EACH METAL CONTAMINATED LOG WITH FLUORESCENT PAINT.
- IT CAN BE DONE! WITH THE INSTALLATION OF ADDITIONAL SHIELDING EXTENSIONS ON THE INLET AND OUTLET SIDE OF THE DETECTION COIL THE "METAL FREE ZONE" CAN BE REDUCED TO A MINIMUM. THIS WAY MESUTRONIC METAL DETECTORS CAN BE USED, EVEN IF SPACE IS AT A PREMIUM.
- SPLINTER DETECTORS MADE IN GERMANY SAVE MONEY AND AVOID PROBLEMS.

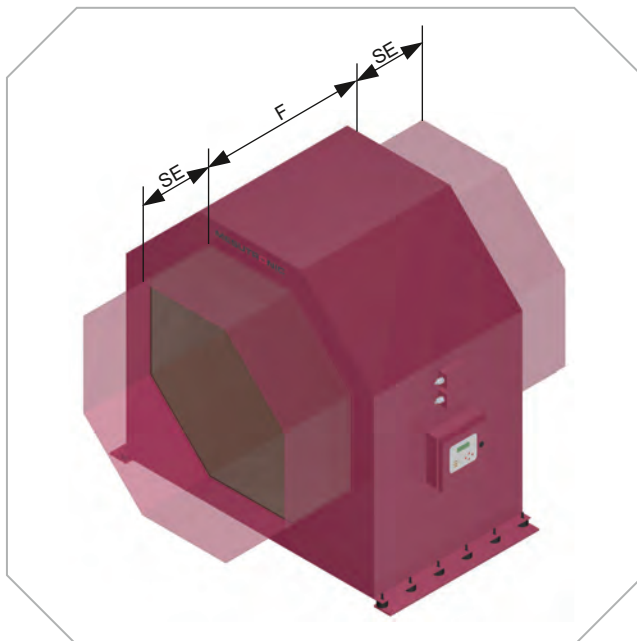

EXAMPLE: SPLINTER DETECTION MACHINE WITH SHIELDING EXTENTIONS (SE).

Typ	SE	F
900	300	800
1000	300	900
1100	400	900
1200	400	900
1300	400	1000
1400	450	1000
1500	450	1000
1600	450	1100

ALL DIMENSIONS IN MM.

IN EXCEPTIONAL CASES, FOR EXAMPLE WHEN STRONG EXTERNAL DISTURBANCES AFFECT THE SPLINTER DETECTOR, OR IF THERE IS VERY LITTLE ROOM FOR THE INSTALLATION, WE RECOMMEND THE INSTALLATION OF SO CALLED SHIELDING EXTENSIONS. IF NEEDED, THESE PARTS CAN BE RETROFITTED. THE TRANSPORT PATH SHOULD BE LAID OUT IN SUCH A WAY THAT THERE IS SUFFICIENT ROOM FOR THE INSTALLATION. SUFFICIENT ROOM = DETECTOR LENGTH (F) + 2 x SE + 200 MM.

DIMENSIONS

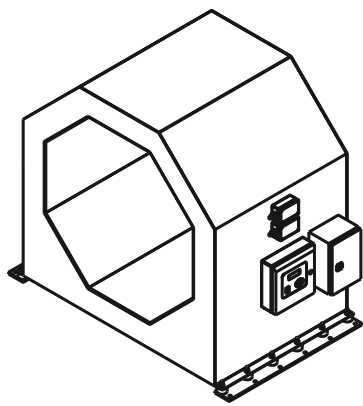
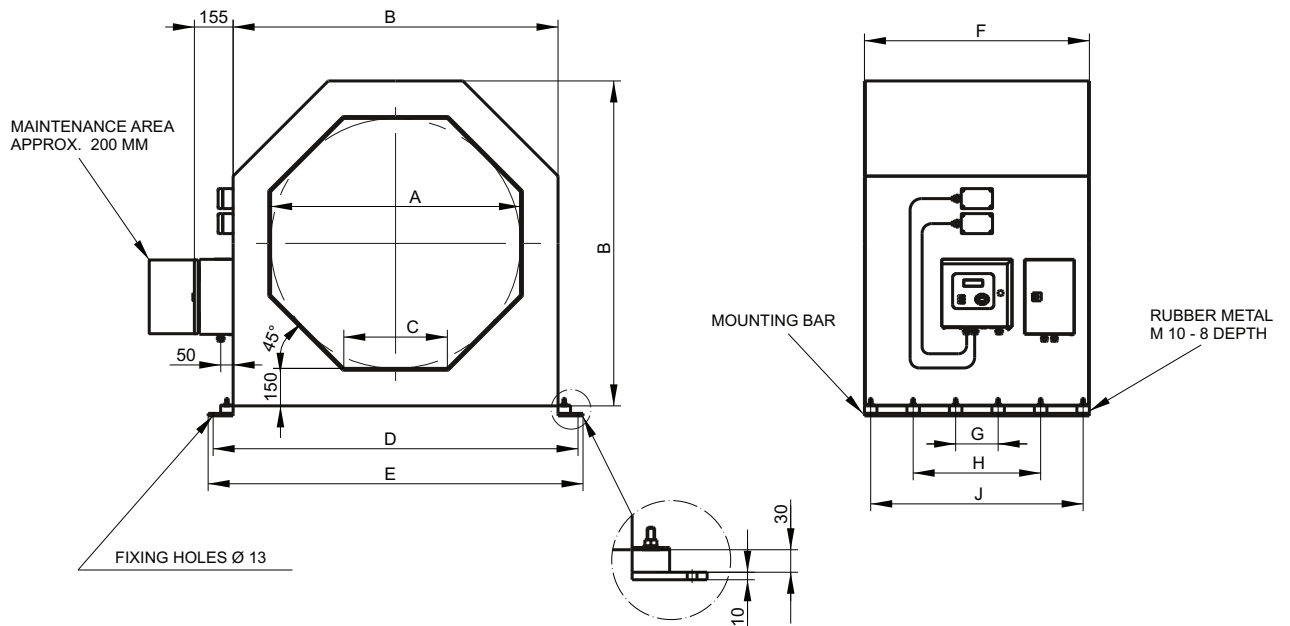

CONTROL BOX (DRILLING PATTERN)

STANDARD VERSION: CONTROL BOX BUILD TO SEARCH COIL

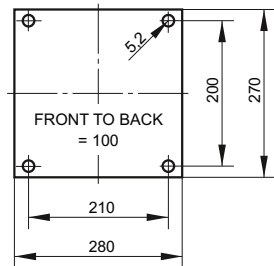

A = TYP

A	B	C	D	E	F	G	H	J	WEIGHT APPROX.
900	1200	372	1360	1400	800	150	450	750	290 KG
1000	1300	414	1460	1500	900	170	510	850	340 KG
1100	1400	455	1560	1600	900	170	510	850	375 KG
1200	1500	497	1660	1700	900	170	510	850	410 KG
1300	1600	538	1760	1800	1000	190	570	950	460 KG
1400	1700	580	1860	1900	1000	190	570	950	495 KG
1500	1800	621	1960	2000	1000	190	570	950	530 KG
1600	1900	662	2060	2100	1100	210	630	1050	580 KG

ALL DIMENSIONS IN MM. OTHER DIMENSIONS AVAILABLE.

METAL FREE ZONE (MFZ)

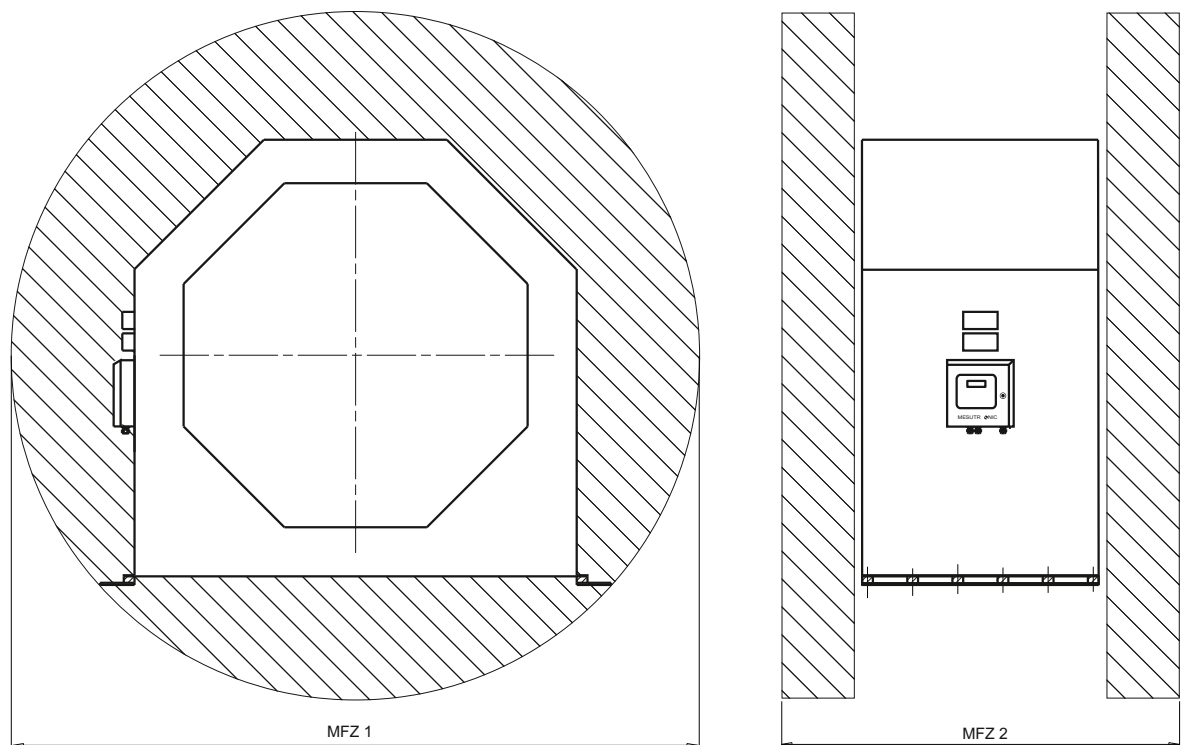

CALCULATING THE „METAL FREE ZONE“..

$$\text{MFZ 1}^{1)} = 2 \times A + B$$

$$\text{MFZ 2} = 2 \times A + F$$

¹⁾ POSITION THE DETECTOR APERTURE IN THE MIDDLE OF THE „METAL FREE ZONE“
FOR THE OTHER DIMENSIONS: POSITION THE DETECTOR SYMMETRICAL IN RELATION TO THE APERTURE.

THE METAL FREE ZONE IS REDUCED WHEN USING A METAL DETECTOR WITH EXTENDED TUNNEL!
MEASUREMENTS FOR THE METAL FREE ZONE ON REQUEST.

THE CALCULATED DIMENSIONS ARE TO BE TAKEN AS ORIENTATION VALUES (MINIMUM VALUES WHICH SHOULD BE EXCEEDED.) AND HAVE TO BE VERIFIED BY THE MANUFACTURER, DEPENDING ON THE PROJECT. MAKE THE „METAL FREE“ ZONE AS LARGE AS POSSIBLE.

PAY PARTICULAR ATTENTION TO MOVING GATES AND MACHINES OR MACHINE PARTS WHICH CHANGE THEIR DISTANCE TO THE METAL DETECTOR OR WHICH MOVE IN THE VICINITY OF THE APERTURE.

IF THE METAL FREE ZONE CANNOT BE MAINTAINED DUE TO SPACE RESTRICTIONS FALSE REJECTS AND OR REDUCED SENSITIVITY CAN BE EXPECTED.

IN ADDITION, PLEASE OBSERVE OUR „HINTS FOR THE INSTALLATION OF SEARCH COILS“.

SENSITIVITY DIAGRAM

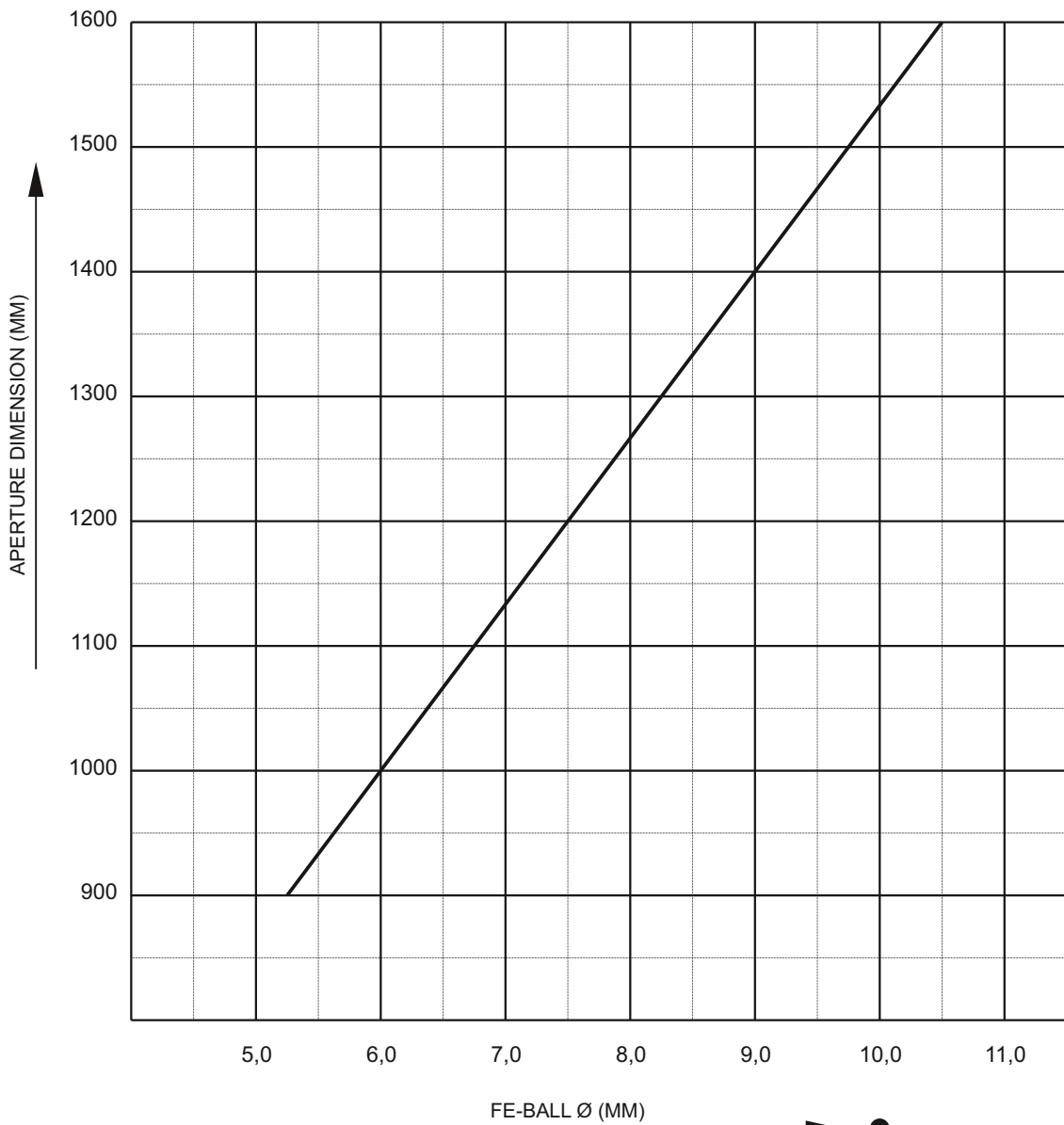

THE SENSITIVITY DEPENDS ON THE APERTURE SIZE I.E. THE SMALLER THE APERTURE HEIGHT THE GREATER THE SENSITIVITY.

THE SENSITIVITIES SHOWN IN THE ADJACENT DIAGRAM WERE ACHIEVED IN THE APERTURE CENTER UNDER BEST PROCESS CONDITIONS.

TO CALCULATE SENSITIVITY FOR OTHER METALS USE THE FOLLOWING MULTIPLICATION FACTOR.

VA (STAINLESS STEEL) = FE-BALL X 1 TO 2
(FACTOR DEPENDS ON THE METAL ALLOY)

CU, ALU, BRASS... = FE-BALL X 1.3 TO 1.6
(FACTOR DEPENDS ON THE METAL TYPE)

CONTROL UNIT AMD 05 (Version 5.2)

ADVANTAGES THAT WILL CONVINCING YOU!

SINGLE BOARD DESIGN WITH BUILT IN REGULATED POWER SUPPLY FOR RELIABLE PERFORMANCE AND EASE OF SERVICE.

AUTO-SETUP-ROUTINE WITH INTERFERENCE SIGNAL SUPPRESSION AND AUTOMATIC SENSITIVITY CALIBRATION.

MULTI-FILTER SYSTEM USING DIGITAL FILTRATION FOR MAXIMUM STABILITY IN HARSH ENVIRONMENTS.

AUTO-BALANCE AUTOMATICALLY DETECTS AND COMPENSATES FOR ANY CHANGES IN THE SIGNAL DURING NORMAL OPERATION. (E.G. TEMPERATURE VARIATIONS)

SELF MONITORING SYSTEM ENSURES ALL IMPORTANT COMPONENTS ARE FUNCTIONING PROPERLY. IN CASE OF A FAULT, RELAY OUTPUTS ARE AVAILABLE. FAULTS ARE DISPLAYED AS TEXT IN REAL TIME.

NARROW DETECTION ZONE PROVIDES AN ACCURATE LOCATION OF THE METALLIC PARTICLE IN THE DETECTION FIELD ALLOWING PRECISE SEPARATION.

TOUCHPAD CONTROLS MODERN DESIGN. RUGGED TOUCHSCREEN FOIL WITH ERGONOMIC CONTROLS.

4 BUTTON TOUCHPAD CONTROLS SUPPORTED BY EASY TO UNDERSTAND MENUS FAST ACCESS TO ALL OPERATING PARAMETERS. USER SELECTABLE DIALOG LANGUAGE.

5-LINE BACK-LIT LCD DISPLAY WITH METAL SIGNAL INDICATION. ADDITIONAL LED INDICATOR LAMPS ARE BUILT IN TO INDICATE METAL DETECTION OR FAULTS.

METAL COUNTER CAN BE DISPLAYED ON THE LCD SCREEN OR INTERFACED WITH A PRINTER OVER A SERIAL INTERFACE.

3-LEVEL PASSWORD PROTECTION WITH INTER-CHANGEABLE CODE NUMBERS.

METAL DETECTOR NETWORK AND REMOTE SERVICE

EVERYTHING IS DO-ABLE! SEVERAL OPTIONAL SOFTWARE-PACKAGES ARE AVAILABLE. EXAMPLE: WITH THE BUILT-IN CAN-BUS-DATA PORT A NETWORK OF UP TO 125 METAL DETECTORS / SEPARATORS CAN BE OPERATED. THE UNITS CAN THEN BE REMOTE CONTROLLED AND OPERATED VIA A CENTRAL PC. ALSO REMOTE DIAGNOSIS, PARAMETER CHANGE AND SOFTWARE UPDATES VIA MODEM ARE POSSIBLE.

SERIAL DATA PORT

FOR DIFFERENT TASKS. THE METAL DETECTOR IS EQUIPPED WITH 1 SERIAL DATA PORT (RS 232). HOWEVER THIS PORT IS RESERVED FOR FACTORY SERVICE ACCESS SUCH AS ADJUSTMENT DATA LOGGING, SOFTWARE UPDATES ETC.) AS AN OPTION, THIS DATA PORT MAY ALSO BE USED BY THE CLIENT (SWITCHABLE). IT CAN BE USED TO DRIVE A LOCAL OR CENTRAL PROTOCOL PRINTER. THE PROTOCOL LAYOUT CONFORMS TO ISO 9000 AND HACCP GUIDELINES. BI-DIRECTIONAL DATA COMMUNICATION WITH CUSTOMER'S SPS OR PC SYSTEMS IS AVAILABLE (OPTIONAL SOFTWARE PACKAGE).



PRODUCT STORAGE MEMORY BACKUP FOR UP TO 500 INDIVIDUAL PRODUCTS. EACH PRODUCT HAS A COMPLETE SET OF ADJUSTMENT DATA ASSIGNED, SUCH AS SENSITIVITY, REJECT TIME ETC. THE DISPLAY OF TIME RELEVANT DATA IS IN REAL-TIME. INDIVIDUAL PRODUCT NAMES CAN BE STORED AS WELL.

ACTIVE QUALITY ASSURANCE

WITH SMD COMPONENTS SAVE NOT ONLY SPACE BUT ALSO ASSURE OPTIMUM QUALITY AND SAFETY FOR THE END USER. WITH AUTOMATED PLACEMENT COMPONENT ERRORS ARE ELIMINATED. IN ADDITION EACH CARD IS 100% TESTED AND ARTIFICIALLY AGED. ALL MESUTRONIC PRODUCTS ARE DEVELOPED UNDER DIN, EN AND UVV STANDARDS AND COMPLY WITH THE STRICT CE STANDARDS AS WELL.

CONTROLS

EXAMPLE OF AN INPUT DISPLAY (DEPENDING UPON THE SELECTED MENU THE DISPLAY SHOWS DIFFERENT FUNCTIONS !)

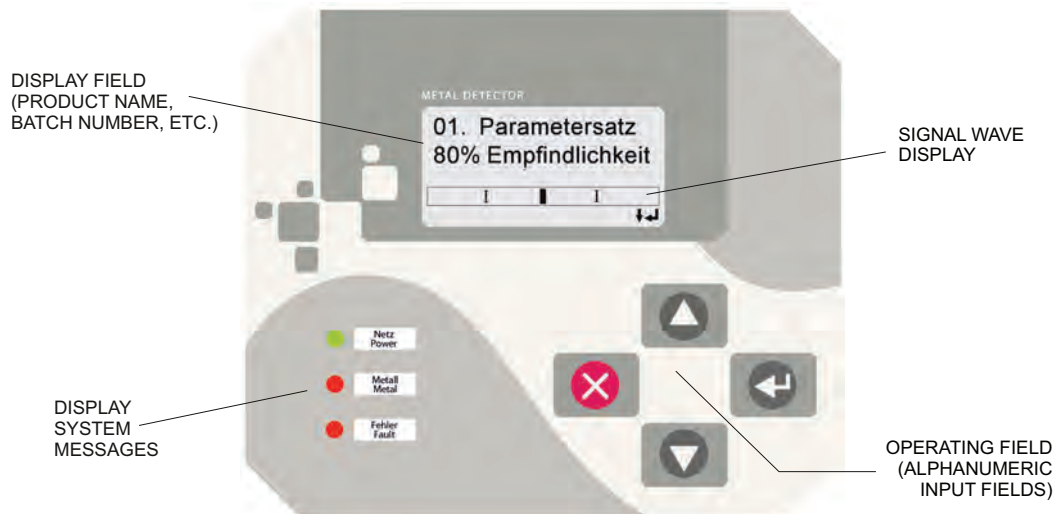

ELECTRONIC BOX

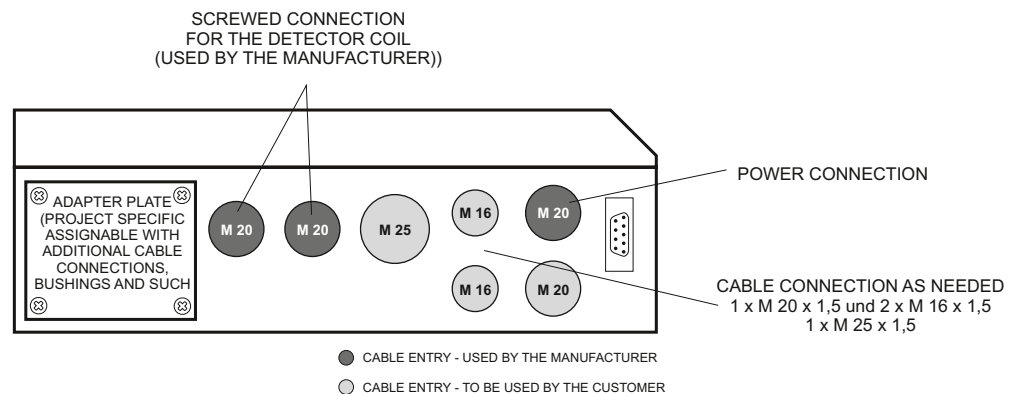

TECHNICAL DATA

POWER SUPPLY:	100 - 240 V AC, 50/60 HZ
POWER CONSUMPTION:	MAX. 50 W
FUSE:	1,25 A (SLOW BLOW); 5 X 20 MM ACCORDING TO DIN
TYPE OF PROTECTION:	IP 65
WORKING TEMPERATURE RANGE:	-10 °C TO +50 °C
STORAGE TEMPERATURE RANGE:	-10 °C TO +60 °C
REL. HUMIDITY:	0 - 95 % (WITHOUT CONDENSATION)
CONVEYING SPEED:	0,05 TO 6 M/SEC.
PAINT:	RAL 3027 = RASPBERRY RED
VERSION:	DETECTOR HEAD = STAINLESS STEEL (1.4301) ELECTRONIC BOX = STEEL (St 37) SENSING AREAS = DUROPLEX
POWER CABLE:	APP. 1,8 M CABLE WITH PLUG (TWO POLE AND EARTHING PIN) (US-VERSION WITH US-STANDARD PLUG)

OTHER VERSIONS AVAILABLE

LAYOUT AMD 05

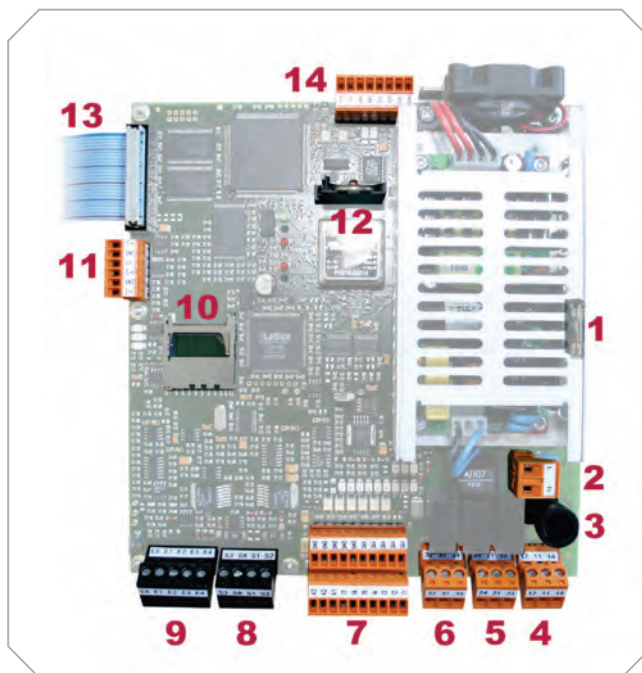

- 1.** SPARE FUSE
- 2.** POWER SUPPLY 100 - 240 VAC, 50/60 HZ
- 3.** DEVICE FUSE 1,25 A (SLOW BLOW) 5 x 20 MM ACCORDING TO DIN



- 4.** RELAY 1 (SWITCHES NORMALLY ON METAL)
POTENTIAL FREE CONTACT
FROM FACTORY (IF NOT REQUESTED OTHERWISE)
RELAY 1 IS DESTINATED AS METAL-RELAY
MAX. CONTACT LOAD: 250 V/3 A



- 5.** RELAY 1 (SWITCHES NORMALLY ON OPERATION)
POTENTIAL FREE CONTACT
ASIDE FROM THE OPTICAL DISPLAY A POTENTIAL FREE
CONTACT IS AVAILABLE TO POLL THE UNIT CONDITION
MAX. CONTACT LOAD: 250 V/3 A



- 6.** RELAY 3 (TO BE CONFIGURED BY THE MANUFACTURER)
POTENTIAL FREE CONTACT
MAX. CONTACT LOAD: 250 V/3 A

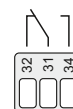

LAYOUT AMD 05

- 7.** SEVEN (7) FREE PROGRAMABLE INPUTS (24V DC)
AND THREE (3) FREE PROGRAMABLE OUTPUTS (24V DC)

In1 - INITIATOR / BUTTON „NORMAL POSITION“
In2 - INITIATOR / BUTTON „EJECT POSITION“
In3 - AIR PRESSURE MONITOR (PRESSURE SWITCH)
In4 - INPUT LIGHT BARRIER
In5 - POSITION SENSOR
In6 - EXTERNAL RESET BUTTON
In7 - NOT CONNECTED

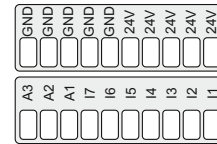

THREE (3) FREE PROGRAMABLE OUTPUTS (24V DC)
OUTPUTS (STANDARD LAYOUT)
OUT 1 - 24 V OUTPUT METAL
OUT 2 - 24 V OUTPUT READY
OUT 3 - NOT CONNECTED

ADDITIONAL CONTACT POSSIBILITIES: LEVEL SENSORS AND MORE

MAX. LOAD FOR ALL INPUTS AND OUTPUTS $I_{TOTAL} \leq 300 \text{ MA CUMULATIVE!}$

- 8.** CONNECTION SENDER (USED BY FACTORY)
9. CONNECTION RECEIVER (USED BY FACTORY)
10. SLOT FOR SD MEMORY CARD
11. CAN – BUS DATA PORT
12. BATTERY
13. CONNECTION DISPLAY (USED BY FACTORY)
14. SERIAL DATA PORT (USED BY FACTORY)

INSTALLATION AND OPERATION INSTRUCTIONS

THE CONVEYOR BELT HAS TO BE EQUIPPED WITH A LARGE ENOUGH „METAL FREE ZONE“ (SEE - SPECIFICATION DATA SHEET - DIMENSIONS). THE METAL DETECTOR HAS TO BE CENTERED WITHIN THE „METAL FREE ZONE“. FURTHERMORE, IT IS ALSO IMPORTANT NOT TO ALLOW DIRECT MECHANICAL CONTACT BETWEEN THE SCANNER HEAD (SEARCH COIL) OR ANY OTHER MOTOR AND FACILITY PARTS.

WITHIN THE „METAL FREE ZONE“ ONLY ELECTRICAL NON-CONDUCTING MATERIAL SHOULD BE USED SUCH AS WOOD OR PLASTICS. PLEASE CONSIDER THAT EMPLOYING A PLASTIC SLIDING PLATE WILL PROMOTE A STATIC CHARGE. THE CONVEYOR BELT ALSO NEEDS TO BE FREE OF ALL METAL (E.G. RUBBER BELT WITHOUT STEEL ROPE INSERTS AND METAL CLIP JOINTS).

THERE CANNOT BE ANY MECHANICAL CONTACT BETWEEN THE PRODUCT, CONVEYING BELT AND THE SLIDING PLATE. THE SLIDING PLATE HAS TO BE SIZED OR SUPPORTED SO THAT THERE IS NO MECHANICAL CONTACT WITH THE SENSORY PLANE BELOW. PRODUCTION RESIDUE, WHICH IS DEPOSITED DURING PRODUCTION, IS TO BE REMOVED REGULARLY. AVOID CONTACT OF THE RETURNING CONVEYOR BELT WITH THE DETECTOR HOUSING (THIS CAN HAPPEN WHEN OVERSTRETCHING THE BELT AT STARTING MOMENTUM).

A FOUNDATION BASE IS TO BE DESIGNED AT THE CONSTRUCTION SIGHT. THE FOUNDATION BASE WILL HOLD THE DETECTOR COILS AND WILL NEED TO BE MOUNTED ON CLAMPING LATHES. THERE HAVE TO BE SEPARATE FOUNDATIONS FOR THE CONVEYING INSTALLATION AND THE METAL DETECTOR TO ENSURE THAT NO VIBRATIONS ARE CARRIED OVER TO THE METAL DETECTOR.

POWER-DRIVEN PULLEYS, DIVERSION PULLEYS, AND NECK PULLEYS ARE POTENTIAL SOURCES OF INTERFERENCE, BECAUSE DEFECT OR POOR BEARINGS SUBJECT THE ELECTRICAL CONTACT TO HIGH VARIATIONS. ATTENTION: TO BYPASS THE POOR CONTACTS WITH GROUNDING STRIP OR GROUNDING WIRE WILL NOT REMEDY THE SITUATION. THE SAME IS TRUE FOR ROTARY-BEARING BOTTOM CORD STRIPPERS, WHOSE PARTS HAVE TO BE PLACED OUTSIDE OF THE „METAL FREE ZONE“.

FOR OUTDOOR USAGE (CONSTRUCTION OUTDOORS), THE METAL DETECTOR HAS TO BE PROTECTED FROM THE INFLUENCES OF THE WEATHER (DIRECT SUNLIGHT, WIND). A WOODEN HOUSING SHOULD BE USED. (DO NOT USE METAL IN THE CONSTRUCTION OF THE WALLS AND ROOFING MATERIAL). THE WOODEN HOUSING HAS TO BE SIZED LARGE ENOUGH SO IT DOES NOT COME IN CONTACT WITH THE DETECTOR COIL.



EXAMPLE

INSTALLATION AND OPERATION INSTRUCTIONS

THE METAL DETECTOR SHOULD NOT BE EXPOSED TO HIGH ELECTROMAGNETIC FIELDS. POTENTIAL SOURCES OF INTERFERENCE ARE: DIRECT CURRENT VOLTAGE MOTORS, AS WELL AS POWER EFFICIENT THREE PHASE ALTERNATING CURRENT MOTORS, IF THEY ARE LOCATED CLOSELY TO THE METAL DETECTORS. IN ADDITION, FREQUENCY REGULATED MOTORS, AS WELL AS SERVODRIVES. OTHER SOURCES OF INTERFERENCE ARE CABLE TRENCHES, WHICH RUN SUPPLY LINES TO AND FROM FREQUENCY REGULATED MOTORS.

IF USING DETECTORS WITH SEPARATE ELECTRONICS, THE JUNCTION CABLES, TRANSMITTER/RECEIVER HAVE TO BE INSTALLED SEPARATELY (SUITABLE PLASTIC WASHERS AND INSULATION NIPPLES ARE INCLUDED WITH THE ASSEMBLY ACCESSORIES).

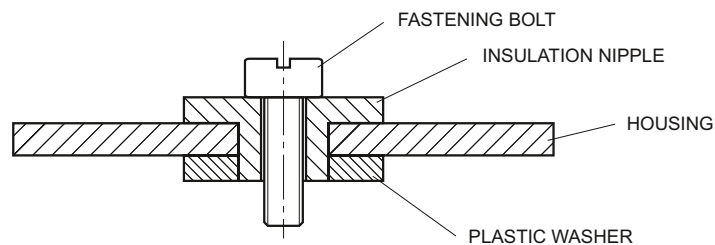

TO ENSURE STABLE OPERATING CONDITIONS, THE METAL DETECTOR SHOULD BE CONTINUOUSLY SUPPLIED WITH POWER (ESPECIALLY USING IT FOR OUTDOOR PURPOSES). WE ALSO URGENTLY RECOMMEND TO CHECK THE SELF-MONITORING SYSTEMS (WHICH DETECTS FAULTS). THIS GUARANTEES THE OPTIMAL SAFETY OF THE FOLLOWING EQUIPMENT.

THE TRANSPORTING EQUIPMENT (CONVEYOR BELT) HAS TO BE CONTROLLED, SO THAT THERE ARE NO PRODUCTS (TREE TRUNKS) ON THE PASSAGE AREA OF THE CONVEYOR BELT, AFTER SWITCHING IT OFF. IF THIS CANNOT BE REALIZED, THERE IS A CHANCE OF LOSS OF SENSITIVITY AFTER RESTARTING.

IF SEVERAL METAL DETECTORS ARE OPERATING IN THE SAME PRODUCTION HALL, NECESSARY SPACING HAS TO BE MAINTAINED. OTHERWISE FREQUENCY DEVIATIONS COULD CAUSE INTERFERENCE.

FOR CLOSED TUNNEL DETECTORS, TYPE CO NOTE:

MINIMUM SPACING = $10 \times LH$ (LW), IF THE DETECTOR COILS ARE PLACED IN PARALLEL (ROW).

THE MINIMUM SPACES CAN BE IGNORED ONLY IF WORKING WITH FREQUENCY SHIFTING. WE RECOMMEND DISCUSSING THIS EARLY ON WITH OUR DISTRIBUTION OR APPLICATIONS DEPARTMENT.

THE METAL DETECTOR SHOULD BE LIFTED ONLY WITH TEAR-PROOF MOVING BELTS.

IF YOU HAVE FURTHER QUESTIONS, DO NOT HESITATE TO CONTACT OUR APPLICATION DEPARTMENT.

Service and Calibration

Bunting service engineers are available at short notice to service and calibrate our full range of detectors in the UK and overseas. Bunting offers 3 levels of protection designed to provide specific services to optimise the performance and lifespan of metal detection equipment

Pro-Start™

Pro-Start™ commissioning coverage ensures that a metal detector performs to company expectations from its first day on the job. A factory-trained service technician will be on-site to verify the installation, calibrate the metal detector to achieve top performance and train personnel. Pro-Start includes a calibration label for the detector, a complimentary set of test pieces (specify size and type on purchase) and a detailed calibration record for company files. It also extends the original one-year factory warranty to two years and includes two years of phone-based technical support.

Pro-Maintenance™

Pro-Maintenance™ keeps the metal detector operating like new, which is critical, considering the impact of poor performance on customer satisfaction and other consequences. It provides either annual (Gold plan) or biannual (Platinum plan) visits by factory-trained service technicians to service and calibrate the metal detector and ensure the system is running the latest accurate software. The Pro-Maintenance plan also includes significant parts and labour discounts on any needed spares and repair work, on-site training for personnel during service & calibration visits and two years of phone based technical support.



OPTIMAL ADAPTED



RELIABLE SYSTEM SOLUTIONS



Burnt Meadow Road, Redditch, Worcestershire, UK, B98 9PA

Tel: +44(0)1527 65858

E-Mail: sales.redditch@buntingmagnetics.com • www.mastermagnets.com